

# RESIDENT DESIGN GUIDELINES



Landscape  
Sustainable  
Landscapes  
Fencing  
Architectural  
Prohibited Plants  
and Trees  
Definitions

Updated April 2024  
All previous versions null and void.

# Table of Contents

<b>Introduction</b> .....	<b>3</b>
Vision Statement .....	3
Overview and Purpose .....	3
Conditions, Covenants and Restrictions (CC&RS) .....	3
Design Review Committee.....	3
Applicability and Implementation .....	3,4
<b>Requirements Applicable to All Improvements</b> .....	<b>5</b>
Design Committee Review, Approval and Timing .....	5
Design Review Fee .....	5
Fee Schedule for Professional Consulting Assistance for Major Architectural/Landscaping Modifications .....	6
Fines for Non-Approved Installations.....	6
Blue Stakes .....	6
Public Utility Easements (P.U.E) Utah Code 54-3-27 .....	6
Swale Drainage Easements* .....	6,7
Use Easements* .....	7
<b>Landscape Guidelines</b> .....	<b>8</b>
Planting Requirements .....	8
Foundation Plantings.....	8
Fence Plantings.....	8
Alley/Lane Plantings .....	8,9
Side yard Plantings.....	9
Hardscape & Plantings .....	9
Specific Plant Requirements .....	9
Lawn .....	9
Shrubs.....	9
Perennials .....	10
Annuals.....	10
Hanging Plant Baskets.....	10
Artificial Plants.....	10
Topsoil .....	10
Trees .....	10,11
Ground Cover .....	11
Hedges .....	11
<b>Additional Guidelines</b> .....	<b>12</b>
Architectural Lighting .....	12
Additional Lighting Requirements (See Appendix) .....	12,13
Internal Accessory Dwelling Unit Aesthetic Requirements (IADU) .....	13
Artificial Turf.....	14
Basketball Goals, Standards, Backboards .....	14
Boulders .....	15
Cameras .....	15
Decking .....	15
Dog Runs .....	15
Edging .....	15
Flag Poles .....	15
Garden Structures (Fountains, Statues, Benches, Garden Boxes, Birdbaths, Bird Houses and Bird Feeders, Etc.) .....	15,16
Garden Structures (Trellises, Pergolas Arbors) .....	16
Gazebos.....	16
Generators.....	16
House Numbers .....	16
Landscape Walls (Garden Walls and Retaining Walls) .....	17
Mulch.....	17
Outdoor Patio Furniture.....	17
Park Strip Pathways.....	17
Parking Pad.....	17,18
Paving.....	18
Play Elements (Swings, Slides, Trampolines, Etc.) .....	18

Satellite Dishes .....	18
Shade Coverings/Shade Sails/Screens .....	18
Sheds .....	19
Shutters .....	19
Sport Courts .....	19
Trash Enclosures.....	19
Vegetable Gardens .....	20
Water Features (Pool, Hot Tub/Spa, Pond, Etc.).....	20
Window Boxes .....	20
<b>Sustainable Landscapes.....</b>	<b>21</b>
Reduction of Heat Island Effect.....	21
Water Conservation .....	21
<b>Reduction of Storm Water Runoff .....</b>	<b>22</b>
<b>Fencing Guidelines .....</b>	<b>23</b>
Fencing Material.....	23
Front Yard Fencing.....	23
Rear Yard & Interior Side Yard Fencing .....	23
Screen.....	23
Street Side Yard Fencing (Single Family Lots Only) .....	24
Street Side Yard Fencing (Townhomes and/or Condominiums) .....	24
Trash Enclosures.....	24
<b>Fence Design Requirements .....</b>	<b>25</b>
Pilasters .....	25
Caps .....	25
Rails .....	25
<b>Architectural Guidelines.....</b>	<b>26</b>
Chimneys .....	26
Cladding .....	26
Color .....	26,27
Columns .....	27
Eaves.....	28
Front Doors, Garage Doors, Storm Doors and Security Doors .....	28
Greenhouses .....	28
Gutters and Down spurts .....	28
Masonry.....	29
Porch and Stair Railings.....	29,30,31
Roofs .....	32
Shingles.....	32
Siding .....	32
Soffits.....	32
Solar Panels.....	32
Storm/Security Doors .....	32
Trellis and Pergolas.....	32
Windows.....	32
<b>Prohibited Plants and Trees in Daybreak.....</b>	<b>33</b>
<b>Definitions .....</b>	<b>34,35</b>
<b>Flip The Strip.....</b>	<b>36</b>
<b>Appendix.....</b>	<b>37</b>

# Introduction

## Vision Statement

Located at the base of the Oquirrh Mountains, Daybreak is a mixed-use, walkable community with a full range of services and amenities. The 4,127 acres at Daybreak comprise the largest development parcel in single ownership in the Salt Lake Valley, with 13,667 homes and over 9,075,000 square feet set aside for commercial and industrial use. Daybreak presents a unique opportunity to shape the Salt Lake Valley's future. Sustainable environmental design strategies have been employed throughout Daybreak, complementing its nature as a mixed-use community with employment, residential, retail, recreational, and civic uses.

## Overview and Purpose

The Daybreak Resident Design Guidelines have been created to establish design criteria for architecture, landscape architecture and sustainable concepts envisioned for all property owners/residents of Daybreak. These design criteria will assure property owners/residents within Daybreak that all individual improvements will conform to the same high standards of design excellence and ensure that the intent of the community vision, planning and design philosophies are carried out throughout Daybreak. The purpose is to achieve overall visual continuity, a sense of thematic consistency within each village and to unify the design and character throughout Daybreak.

These design guidelines may be amended from time to time, and it is the responsibility of each resident to obtain and review a copy of the most recently revised version of the guidelines. In addition to conforming to these guidelines, all construction must conform to all applicable ordinance requirements of the City of South Jordan and any other governing agencies.

## Conditions, Covenants and Restrictions (CC&Rs)

These Design Guidelines are in addition to any other recorded declaration of covenants, conditions, restrictions and easements (CC&Rs). These Design Guidelines are subordinate to the easements, the Articles of Incorporation, the Bylaws and any recorded tract declaration the lot or parcel may be subject to.

## Design Review Committee

A Design Review Committee (DRC) has been established through appointment by the Board of Directors of Daybreak. The Design Review Committee is responsible for reviewing all proposed changes, modifications, or additions to the exterior of each home, to include but not limited to structural changes, landscaping, walls, fences, gates, driveways, walkways, pools, and in essence, anything visible from a public street (including alleys) or common area.

All proposed changes, additions and improvements must be submitted to the DRC for approval, and no work may begin without the approval of the DRC. Any changes, additions or improvements made without required prior DRC approval may be cited as a violation and be subject to a fine by the Association.

## Applicability and Implementation

These Design Guidelines are authorized to be used by the Daybreak Design Review Committee (DRC) in evaluating the merits of subsequent proposed development within Daybreak. The Community Founder, under the adopted Declaration, has the exclusive authority to interpret,

amend and add to any of the standards contained within this document.

The implementation and enforcement of the standards in this document will be through the DRC, which will be responsible for design reviews and approvals.

These standards are specifically directed at the evaluation of residential uses, but they are to be used in concert with related standards where overlap exists. The following apply to the implementation of these standards:

- These standards are binding on any person or entity intending to construct, reconstruct or modify any residential property or improvement, or in any way alter the site of Daybreak.
- The standards and the associated design review procedures established in this document are the criteria and process by which the DRC will review, approve or disapprove individual projects.
- The standards are subject to change when the DRC determines such change is in the best interest of Daybreak.
- Adherence to these design guidelines does not remove responsibility to conform to local, state and national codes and regulations.
- Where differences exist between these standards and any City of South Jordan ordinances, the more stringent ruling shall prevail.
- The DRC shall have the rights and powers conferred upon it by the CC&Rs.
- The DRC is responsible for the administration of and compliance with the community Design Guidelines.
  - If any applicant fails to comply with these Design Guidelines, the DRC shall have the right to bring compliance or commence appropriate legal action and collect to recover all the costs associated with its actions.
  - The DRC reviews submittals for proposed improvements solely for aesthetics and compatibility with the community.
- The DRC has adopted these standards and it is the responsibility of the DRC to review, study and approve or disapprove any proposed improvements or development in Daybreak based on the standards established.

Any review, study and/or approval by the DRC shall not constitute an approval, ratification or endorsement of any life-safety aspects of the improvements, the quality or architectural or engineering soundness of the proposed plan or improvements, nor the suitability of the improvements for its intended use. Neither the DRC, its members, nor officers of the HOA, shall have any liability in connection with, or related to, approved plans, specifications, or improvements.

Further, once an applicant has received final design review approval from the DRC, and the project has been constructed and approved as consistent with the DRC's approved plans and specifications, the project improvements shall be maintained in the originally approved style and character, including architecture, landscape architecture, color, signage detail and design character. Any proposed variances from the original design and development character approved by the DRC shall be submitted to, and approved by, the DRC.

# Requirements Applicable to All Improvements

## Design Committee Review, Approval and Timing

- All Landscaping and Architectural Modifications must be approved by the Design Review Committee for Daybreak prior to installation to prevent Notice of Violations or violation fines. All modifications installed without prior approval are subject to fines including but not limited to removal at the Committee's discretion and owner's expense.
- Sub Association Approvals: If you live in a townhome or condominium, it is important to note that prior to approval by the Design Review Committee for Daybreak, all Landscaping and architectural modifications are subject to final approval by your Sub Association's Board of Directors.
- Applications can be found at the Daybreak Community Association Office at 11248 S. Kestrel Rise Road, Suite 201, and online at <http://www.MyDaybreak.com>
- Any questions, please contact the Association office at 801-254-8062.
- A homeowner has up to 1½ years from the time of closing on the home to complete the required landscaping improvement and receive approval from the Design Review Committee.

## Design Review Fee

- Fees must be paid by **check or money order** at the time of submittal to the Daybreak Community Association Office.
  - \$250.00 (non-refundable) for major Architectural Modifications
    - Includes but not limited to: All proposed changes, modifications, or additions to exterior structure of the home.
    - Additional fees may be charged for complex architectural modification or landscape applications requiring additional professional review and assistance. \* Please see fee schedule below
  - \$75.00 (non-refundable) for Major Modifications & \$25 for Park Strip Applications
    - Includes but not limited to: Landscaping projects, back yard completion, fences, pergolas, decks, patios, edging, retaining walls, play structures, trampolines, water features, fire pits, light posts, shade structures, flag poles, sheds, sport courts, etc.
    - Repainting of home with new color palette or scheme.
  - \$125.00 (non-refundable) for Variance Requests
    - If more information is needed or if the project presents the need for an exception from the Design guidelines and must be reviewed by the Covenants Committee and the Board of Directors.
    - Fee is due in addition to initial Design Review Fee.
  - FREE for Minor Modifications (No submittal is required for minor modifications).
    - Enhancements to existing flower beds and lawns consistent with approved guidelines and original materials such as: planting bulbs, planting annuals, fertilization, pruning, replacing bark mulch or ground covers, routine maintenance, raiing, adding non-permanent paths within flower beds and replanting or replacing dead plants in existing beds or replacing sod in lawn areas.



- Non-permanent paths within flower beds and replanting or replacing dead plants in existing beds or replacing sod in lawn areas.
- Repainting of a home with an identical color palette and scheme.

## **Fee Schedule for Professional Consulting Assistance for Major Architectural/Landscaping Modifications**

- Project discussion with staff member: Free (see above)
- Initial application and site plan submission: \$250.00
- 1st Review and meeting with professional design consultant: Additional \$500.00 per hour
- 2nd additional meeting and review: \$750.00
- 3rd additional meeting and review: \$1,000.00
- After the 3rd meeting and review: Hourly professional consulting fees apply

After the 3rd meeting: \$2500 Escrowed fees (or higher) would be required to cover consultant time, any fees not used would be returned to the homeowner. Additional fees beyond the escrow may be required as the process continues.

## **Fines for Non-Approved Installations**

Installations that have not been previously approved by the DRC may be noticed as a violation, and the owner of the property subjected to a fine by the Association. Owners of properties containing non-approved installations are advised to apply for DRC approval and comply with the terms of such approval before being issued a notice of violation in order to avoid being fined.

## **Blue Stakes**

It is required by law to call Blue Stakes no matter how deep you are digging, since many cables and pipes lie at extremely shallow depths. A copy of the results must accompany your final submission (SM) Call before you dig! Dial 811 from anywhere in Utah, 801-208-2100 in Salt Lake Metro or toll free at 800-662-4111 or submit your request online at [www.bluestakes.org](http://www.bluestakes.org).

## **Public Utility Easements (P.U.E.) – Utah Code 54-3-27**

- A public utility easement provides utility companies the right to install, maintain, operate, repair, remove, replace, or relocate public utility facilities.
- If a property owner places improvements that interfere with the easement rights, the property owner shall bear the risk of loss or damage to those improvements resulting from the utilities needing to be installed, maintained, operated, repaired, removed, replaced or relocated.
- When necessary, a copy of the approved change will be required with your Design Change Application.
- It is the homeowner's responsibility to determine PUE applicability to their design review application.

## **Swale Drainage Easements\***

- A drainage swale is identified by its shaped and sloped depression in the soil surface that is engineered to convey water run-off to a desired location and cannot be blocked, obscured or covered.

- Not all lots have a Swale Drainage Easement. If your lot has a drainage swale, it will be shown on your lot-specific site plan and/or recorded plat that may be provided by the home builder or South Jordan City.
- Property owners must provide for the proper maintenance and continued operation of Swale Drainage Easements located on their property so that neighborhood drainage continues to operate as originally planned.
- Any questions, please contact the Association Office at 801-254-8062.

### **Use Easements\***

\*See closing documents for individual use easement assignments that are lot specific.



# Landscape Guidelines

All landscaping and architectural modifications must be approved by the Design Review Committee for Daybreak prior to installation.

## Planting Requirements

- It is a requirement that plantings are present surrounding the following locations:
  - Foundations
  - Fences
  - Alley/Lane
  - Plants are required to be spaced 3 to 5 feet apart on center. Perennial spacing: 18 inches on center, depending on species type.
  - All planting areas are recommended to contain 8-12 inches of topsoil and 4 inches of either organic bark consistent across the property or rock within park strips only. No synthetic mulch or bark is permitted, as this material does not biodegrade and may cause problems when washed into storm drainage facilities. (no red, black or white rock)
- Weed control fabric or pre-emergent weed control is recommended for all planted areas.
- It is a requirement that a continuous edge between the plant bed and lawn is present.
- Pre-made edging such as composite or steel pre-made edging will be allowed. Shovel cut edging is the preferred Daybreak edging; however, it must be regularly maintained.
- Concrete curbing is allowed in Village 1 only (Founders Park).

## Foundation Plantings

- A minimum of a 2' planter bed with foundation plantings is required at the base of houses and garages.
- Foundation plant layering.
  - Plantings should reflect a vertical layering effect composed of low, medium and tall plant material. Plant layering must terrace upward as it approaches a structure (house) with the tallest material next to the structure. For example:
    - Low = lawn and ground covers
    - Medium = perennials and smaller shrubs
    - Tall = foundation shrubs and hedges

## Fence Plantings

- Must provide a minimum 2-foot-wide foundation planter at the exterior of a privacy fence's base, except when the exterior planter bed would be located on the property line. Planter bed must include drip irrigation and mulch.
- Must provide a minimum 2-foot-wide foundation planter bed at the exterior and interior of the fence base on picket style fencing. Planter bed must include drip irrigation and natural mulch for picket fences. Rock is allowed only behind a 6' privacy fence in a 2' planter bed (no red, black or white rock).

## Alley/Lane Plantings

- Alley/lane planting zones must be landscaped. These zones are the 2 feet between the rear yard fence and or the alley/lane paving.
- Alley/lane planting zones must utilize shrubs and perennials that do not exceed 4 feet in

height and are tolerant of salt and snow loads.

- Plant minimum size requirements in the alley/lane planting zones are:
  - 1-gallon shrubs
  - 4-inch pots for perennials and ground covers

### Side Yard Plantings

- Plantings, drip irrigation and **natural** mulch are required in narrow side yards. (see foundation planting requirements above (no red, black or white rock)

### Hardscape & Plantings

- Pavers, decomposed granite, flagstone are permissible including planter beds and perennial plant material incorporated into backyard design. See requirements above.

### Specific Plant Requirements

All landscaping and architectural modifications must be approved by the Design Review Committee for Daybreak prior to installation.

#### Lawn

- Lawn areas must be large enough for practical use and be located no closer than 2 feet from foundations (house and garage) and 2 feet from fences and tree trunks.
- Lawn areas shall not exceed the greater of 250 square feet, or 35% of the total landscaped area.
- Artificial turf is not permitted in areas of public view. Please see requirements on [mydaybreak.com](http://mydaybreak.com)
- Lawn area shall not be less than 8 feet wide at its narrowest point.
- Small residential lots, which have no back yards, which the total landscaped area is less than 250 square feet, and which the front yard dimensions cannot accommodate the minimum 8 feet wide lawn area requirement of the landscaping requirements are exempt from the 8 feet minimum width lawn area requirement. This will be determined "at the discretion of the Design Review Committee"

#### Shrubs

- Minimum size at installation is 5 gallon; 1 gallon in alley planting zones. Zones must utilize shrubs that do not exceed 4 feet in height and are tolerant of salt and snow loads.
- Shrub Spacing: varies depending on species type; never more than 5 feet on center.
- Planting plans are encouraged to have a mix of both evergreen and deciduous plants for year-round visual interest.
- Starting on September 1, 2021, landscapes are recommended to have enough plant material (perennials and shrubs) to create at least 50% living plant cover at maturity at the ground plane, not including tree canopies
- Starting January 1, 2022, when grass is not present in a park strip, plant coverage is required to be 80 – 100% at maturity and not obstruct site lines of drivers

## Perennials

- Minimum plant size at installation is 1 gallon; (4-inch pot in alley/lane planting zone that do not exceed 4 feet in height and are tolerant of salt and snow loads).
- Spacing: 18 inches on center, depending on species type.
- Planting plans are encouraged to have a mix of both evergreen and deciduous plants for all year color.

## Annuals

- Annuals are permitted, however, limited to 25% of planter bed and must be dispersed throughout the planting area with perennials and shrubs for year around visual interest and coverage.

## Flower Pots, Decorative Planters Hanging Plant Baskets, Porch Planter Boxes

- Hanging plant baskets, pots and porch planter boxes are allowed on the front porch.
- Planters, pots, and decorative planter boxes may not be used in place of required plant or plant spacing requirements.
- Decorative planter pots may be used as an accent on porches and minimally in landscape beds but are not to be a dominant element or focal point.
- Porch planter boxes are allowed as long as they are detached from the home and correspond to the architectural style of the home
  - \* If planter box elements are attached to the home, they must be applied for through the Design Review Committee

See guidelines for vegetables, fruits, herbs, etc. on page 20

## Artificial plants

- Artificial plants are not permitted. (See appendix for artificial turf requirements.)

## Topsoil

- Lawn areas: 4-inch minimum
- Planting beds: 9 -12 inch minimum

## Trees

- **Front Yards**
  - Installed by the builder and becomes the homeowner's responsibility to maintain as part of their lot.
  - Must contain a minimum of 1 deciduous tree in addition to trees located in the park strip.
  - 2-inch caliper minimum. 10-gallon pot.
- **Park Strip**
  - Location and amount number outlined on plot plan.
  - 2-inch caliper minimum. 10-gallon pot.
  - Replanted trees must be the same variety as what is being replaced to ensure conformity with street tree requirements.
  - Lawn shall not be installed in park strips on new construction lots starting January 1, 2022.

- Drip lines shall be installed to each tree, separate from turf irrigation.
  - Installed by the builder or Daybreak Communities; however, the homeowner is responsible to maintain.
  - See Appendix for “park strip flips” water-wise plant conversion requirements.
- **Rear Yards**
    - Must contain a minimum of one deciduous shade tree.
    - 1 ½ inch caliper minimum
    - Shall be placed at least 6 feet from property lines.
    - Spacing variance may be granted for smaller homes or are part of a cluster, paseo or cottage court.
- **All Trees**
    - To prevent mechanical damage to trunk, a minimum of 2 feet natural mulched radius tree ring or rectangle from curb to sidewalk is required at the base of the tree and be consistent with the edging in the yard.
    - Deciduous trees should be located to provide summer shade on south/south-western exposures.
    - Tree spacing is dependent on species type.
    - Evergreens must be at least 6 feet in height at installation and spaced appropriately for species and location.
    - Replanted trees on property may be the same variety and does not require DRC approval. When the variety and/or size changes, it requires DRC approval.
    - Parkstrip trees must remain the same species as determined by the board of directors and the developer.
- **Tree Rings**
    - Pavers may be used as a minimum 2' diameter tree ring as long as the pavers are able to be mowed over and level to the ground. All pavers must be approved by the DRC prior to installation.
    - If pavers become uneven or unsightly, they must be re-installed or removed. Tree roots, over time, may push up the pavers; frost heaving may also occur.

## Ground Cover

- Ground cover is defined as living plant material.
- (Unplanted areas of stone, cobble, gravel, bark, or mulch are not permitted.)
- Minimum plant size at installation: Flats.
- Spacing a minimum of 18 inches on center, depending on perennial plant species type.

## Hedges

- Hedges are permitted on all lots and must be maintained on a regular basis.
- Hedges are meant to mark property lines, and walkways and to improve privacy.
- Hedge plantings must be densely spaced 2-3 feet apart on center to create a living wall at maturity.

# Additional Guidelines

All landscaping and architectural modifications must be approved by the Design Review Committee for Daybreak prior to installation.

## Architectural Lighting

- For holiday lighting see [Christmas Light Resolution](#) at [www.MyDaybreak.com](http://www.MyDaybreak.com)
- Low voltage clear landscape lighting is permitted for practical night-time safety and pedestrian circulation.
- Fixtures must complement the architecture and be downward facing to mitigate light pollution and nuisance to neighbors.
- Eave and ground lighting, illuminating structures are not permitted.
- We strive to uphold the concepts of the “Dark Sky Initiative”. Please go to [www.darksky.org](http://www.darksky.org) for more information. Landscape lighting must be low voltage “Up lighting” of trees is acceptable but must be approved by the Design Review Committee prior to installation.
- Permanent, aluminum track lighting may be installed and remain on the exterior of the home all year based on the following requirements:
  - Permanent lighting must be approved by the Design Review Committee prior to installation.
  - No vinyl, PVC or plastic tracks permitted as a permanent fixture.
  - Daybreak Community Association reserves the right to require a resident to modify the brightness and programming of a light display after approved installation if light emission causes a nuisance or disturbance to neighboring properties.
- Non-permanent, string Christmas lighting and displays may be installed beginning October 1st and may be illuminated between November 15th and January 15th of each year. Christmas light displays must be removed from the exterior of the home by April 1st of the following year.
- Non-permanent wires and bulbs are to not be visible on the exterior of the home prior October 1st and removed by April 1, the following calendar year.
- Both permanent and non-permanent lighting may be illuminated between November 15th and January 15th each calendar year.
- See Holiday Display and Lighting Resolution – (see attachment X)

## Additional Lighting Requirements – See Appendix

1. All lighting should be low level and recessed to shield the source of light.
2. All fixtures and lights must be submitted in lumens versus watts. Lumens refer to the brightness of the light and wattage is a measure of power to produce the light. Lights may not be more than 600 lumens. Colored lamps/bulbs are not allowed. In areas where accent or access lighting is desired, low voltage lighting is preferred because of its ability to produce dramatic lighting effects using extremely low wattage lamps. Lighting design should consider the use of down lights or up lights to lessen the impact to the nighttime sky. Use lighting in moderation as needed to produce reasonable and safe visibility for access or accent. Fixtures, lamps, and lights must comply with the Dark Sky Initiative and the device shall not provide illumination in excess of .25 foot-candles at the property line.
3. Light bulbs selected for exterior fixtures should be warm in color, with a color temperature of 2700K or lower.

4. Spotlights and floodlights are prohibited in front yards. If spotlights and floodlights are installed in the backyard, they may not be directed at or shine on a neighbor's home, property or on the common area and should be integrated into the architecture of the home. Light fixtures may not be replaced by motion detectors or security cameras. Floodlights and spotlights should have a color temperature of 3000K or lower.
5. The maximum height of any house mounted outdoor lighting source shall be twelve feet (12') above the finished grade at the base of the light standard.
6. Electrical, fence post lighting, pathway or solar light fixtures are approvable based on the architectural compatibility with the home and must be submitted for approval by the Design Review Committee, prior to installation. All solar light fixtures must be low lumens and spaced a minimum of 4' apart.
7. Design light fixture enclosures to conceal the fixture and direct the light downward.
8. No lamp post lights will be permitted in front or back yards.
9. Shrubs shall be used to be used to blend with landscape lighting fixtures. Junction boxes must be placed below grade to minimize daytime visibility of the hardware.

The Board of Directors reserves the right to require the removal of lighting and decorative items in front yards based on size, quantity, brightness, color, location and any other criteria relative to other Units in the area. The Board of Directors, at its sole discretion, shall make its determination on a case-by-case basis.

### **Internal Accessory Dwelling Unit Aesthetic Requirements (IADU)**

An Internal Accessory Dwelling Unit is a wholly separate living area within a primary residence. Reference "Questions to ask Before Adding an IADU to your Home" for more information on Internal Accessory Dwelling Units.

Required Prior to Review or Approval of an IADU:

A site plan with elevations must be submitted showing the location of the proposed parking pad location to accommodate the required off-street parking.

On the to-scale site plan, the following elements are required:

1. A minimum of (1) 10' x 18' concrete or paver, off-street parking pad to be in compliance with state and local requirements.
  - a. Proposed dimension of parking pad off street to be in compliance with state & local regulations
  - b. A photo of proposed materials, ie. pavers
  - c. Gravel, decomposed granite (dg) chat, soil, lawn and mulch are not approvable materials for a parking area.
  - d. Property lines and setbacks must be identified on the site plan.  
<https://www.sjc.utah.gov/public-records/grama-request-form/>
2. Perennial plants must be installed and maintained in a 18"- 24" planter bed on 3 sides of parking pad (plant list required on a site plan)
  - a. Perennial plants must be spaced 3'-5' apart on center with drip irrigation to each plant
  - b. Bark mulch of neutral colored mulch is to be included in planter beds and maintained
3. An engineered site plan for an exterior entrance must be included
4. Any grade or slope impact must be identified on site plan
5. Stair railing material, design and location is also required to be submitted. This must match existing railing elements and architectural details of the home, if present.

6. Additional landscape material may be required by the DRC to screen exterior stair entrance.
7. Exterior entrance may not be located in the front of home or be visible front the street.
8. Proposed door design must be submitted.

### **Artificial Turf – See Appendix for description sheet**

- Artificial turf must be applied for and approved by the DRC prior to installation
- All rear-yard fencing and landscape requirements shall apply
- Application must include specifications of product, installation process, irrigation plans and drainage plans
- May not be visible from public view
- Must be behind a 6' enclosed, privacy fence
- A shade tree is required 6' from the fence line\*
- Prohibited in the following locations:
  - Front yards
  - Street-facing side yards
  - Behind picket fences
  - Behind 5' fences
- May be installed only on owner's property
- The turf must be maintained, irrigated and sanitized to not create an unhealthy, untidy or nuisance condition
- Pet waste may not be allowed to accumulate; any odor must be immediately addressed and eliminated
- No stains, tears, ripples or visible seams are allowed to be present
- Proper drainage must be included in turf system to not impact surrounding community or neighboring properties
- Quality, green (only), multi-layered product designed to create the best aesthetic and environmental outcome is required
- Single-layer or roll-type artificial turf is not allowed

### **Basketball Goals, Standards, Backboards**

Basketball courts are considered a modification and installation are subject to the Design Review Committee's approval.

- Basketball goals and basketball standards are considered an exterior modification and require DRC approval prior to installation
- Permanent basketball goals are permissible only in the side or rear yard but must be a minimum of 30 feet from the curb at the front of the home.
- All basketball goals are required to be properly maintained. Damage to backboards, deformed or twisted rims, torn nets and chipped or damaged poles or backboard are not permitted. Clear or transparent, plexi-glass and transparent acrylic are acceptable, as well as neutral shades. Only nylon or similar cord nets are permitted, while metal or chain nets are not allowed.
- Lighting for sports courts or nighttime play is not permitted
- We request that basketball goals are installed in a manner that does not pose a safety hazard. Basketball goals and standards may not cause damage to nearby homes or common areas, or obstruct traffic around the property. The board of directors reserves the right to require removal if deemed a nuisance.



## Boulders

- Boulders are permitted for retaining walls in rear or side yards only.
- Boulders are not permitted for retaining walls in front yards or street side yards.
- If used, boulders must be incorporated into a planter bed with plantings.
- Boulders are permitted. However, when they are used, they must complement the architecture and landscape in size, color, number and placement.
- Boulders must be installed 1/3 below ground for a natural affect.

## Cameras

- Doorbell cameras are permitted
- Camera/light combinations must not violate Utah privacy laws
- Cameras may not replace light fixtures
- Cameras must go through the Design Review Committee process for approval, prior to installation

## Decking (See Appendix)

- Decking is permissible
- **Must coordinate with the architectural style, materials and details of home**
- Must be submitted to the Design Review Committee for review, prior to installation
- Deck may be required to have a railing that matches porch railing if present
- Horizontal deck skirting may be required if a gap is present
- Deck trim must match home trim
- Wood, Trex products are approvable material
- Planting material may be required depending on site location
- Location may not hinder drainage or property setbacks

## Dog Runs

- See [Dog Run Resolution](#) at [www.MyDaybreak.com](http://www.MyDaybreak.com). (see attachment A)

## Edging

- Edging is not intended to be the focal point when landscaping is viewed.
- Preferred edging is shovel-cut but edging material may consist of steel or composite.
- Concrete curbing is allowed in Village 1 only (Founders Park).

## Flag Poles

- U.S and Novelty flags are permitted on poles but should not detract from the home or landscape.
- Please reference Display and Use of United States Flag Policy Resolution and Display and Use of [Novelty Flag Policy Resolution](#) at [www.MyDaybreak.com](http://www.MyDaybreak.com). (see attachment B)

## Garden Structures (Fountains, Statues, Benches, Birdbaths, Bird Houses and Bird Feeders Etc.)

- All garden structures must be consistent with the house's architectural and landscape character and located in a manner which complements both.
- Number of items may be limited by the Design Review Committee and Board of Directors.
- Number of items should be limited so as to not cause a visual or wildlife nuisance to neighboring or community properties

- Whether or not a nuisance exists shall be determined by the DRC, Compliance Committee and or the Board of Directors
- Garden structures should not detract from the home's architecture and aesthetic and be used minimally.
- If item becomes a nuisance in number or function, create an unhealthy or untidy condition, the board of directors reserve the right to require removal or modification

## **Garden Structures (Trellises, Pergolas Arbors) – (Updated 2/2023)**

### **See Appendix for revision sheet**

- Architectural style of structures must be consistent with the architectural style/details of home
- Post size shall be no smaller than 6" x 6"
- Purlin spacing at least 8 inches of clear space.
- Beam dimensions – at least 6 inches.
  - Rafter Spacing - at least 12 inches on center.
  - Color of finish – Daybreak approved gray stain, the home's trim paint color may be submitted to the Design Review Committee as an alternative, approvable finish.
- Materials -- wood or composite with approval from the Design Review Committee – no vinyl.
  - Metal - Durable, rust-resistant metal is required and must match the architectural style of the home. Must be approved by the DRC prior to installation.
- Size, scale and proportion must be consistent with the home.
- No solid roofs are allowed on pergola structures.

## **Gazebos**

- Custom gazebos must coordinate with the architectural style, materials and details of home may be submitted to the Design Review Committee for review

## **Generators**

- Generators are viewed as a utility and are permissible but must be screened from public view behind a 6' privacy fence. An application must be submitted through the Design Review Committee, prior to installation.

## **House Numbers**

Whitehall Hartford 16" x 7.25 plaques are the standard for traditional architecture in Daybreak. Residences with contemporary/modern architecture may be allowed to use a different typeface approved by the Design Review Committee.

- House numbers must be placed parallel to the primary street or open space which the home faces.
- House numbers must be visible from the primary street or open space which the home faces.
- Changing the design/format of the original house numbers may be considered subject to the compatibility of design to the home's architecture, village character and size of numbers to be seen from the primary street or open space which the home faces.
- Size of numbers is 8" maximum and 4" minimum

## **Landscape Walls (Garden Walls and Retaining Walls)**

- Subject to approval by all utility companies.
- Boulders are not allowed in front yards unless part of a planter bed (see Boulders under Additional Guidelines). If wall is greater than 30 inches in height, it must terrace and include a 2 foot to 3-foot-wide planter bed in front.
- For some areas such as the lake front and Watercourse, yards fronting the public realm are considered front yards.
- Retaining walls may not be placed in setbacks, easements or impede drainage swales

### **Mulch - (Updated 6/2023) See Appendix for information sheet**

- Mulched areas must be planted 3 feet to 5 feet apart on center. Unplanted rock/bark mulch areas are not permitted. Park strips are to be more heavily planted 80-100% at maturity
- Minimum 3 inches depth is required in all planter beds and tree rings.
- Rock/bark mulch is not to draw attention or be the main focal point. (no red, white or black rock)
  - Bark or wood mulch must be shredded, natural, neutral in material and dark brown or black in color and must blend with surrounding landscaping.
  - Rock mulch must be natural, neutral, and beige/brown/gray in color and blend with surrounding landscaping. Rock mulch must be no more than 1" to 2" in size. (no red, black or white rock permitted)
- **Rubber mulch:**
  - Rubber mulch is allowed but must be shredded dark brown with no chunks
  - Must be approved by the DRC prior to installation
- **Rock Mulch:**
  - Rock mulch is not permitted in any area except the park strip area.
  - Rock mulch must be 1 – 2" maximum in size and must be natural colored (no red, black, white or pea gravel
  - Decomposed granite (dg) chat, crusher fines are allowed for paths only
  - Rock mulch must be planted with perennial plants, shrubs, ground cover 80 – 100% plant coverage at maturity
  - Rock mulch is approved only for plant beds in park strips, 2' alley plant beds and plant beds behind a privacy fence. Rock mulch is not allowed in the front or side yards.
  - 80 – 100% plant coverage at maturity in the park strip is required.

### **Outdoor Patio Furniture**

- Outdoor furniture such as chairs, tables, settees, or loungers that are designed for outdoor use are permitted (Cloth furniture designed for indoor use is not permitted for outdoor use)
- Weather-resistant materials that will not be damaged by exposure to rain, sun, snow or other outdoor elements are acceptable.

### **Park Strip Pathways**

- Park strips are part of the street right-of-way which is owned and managed by the City of South Jordan. If a pathway or steps are desired within a park strip, the City of South Jordan must give required permission before the Design Review Committee reviews application. A copy of this correspondence must accompany the application.
- Stepping stones or pavers are allowed pathway treatments.
- Proposed concrete addition would require a city encroachment permit.

## Parking Pad

- Parking pads are allowable and may be considered, subject to Design Review Committee approval, when/if it can be demonstrated there is available space and access on the applicant's property without also impeding or placing a burden on neighboring properties.
- The minimum dimension for a parking pad is 10' x 18' with a 2' planter bed and must include perennial plants spaced 3'-5' apart on center on 3 sides of the parking pad
- Parking pad may not be installed to the property/ fence line.
- May not impede positive draining from property or impede drainage swale on property or neighboring properties
- Parking pads are a requirement of South Jordan City for an Internal Accessory Dwelling Unit (IADU) to be permitted.

## Paving

- Pervious paving is required in medium-to-low traffic areas such as garden walks and secondary pathways through the yard.
- Permitted materials for the center of a Hollywood drive include lawn, brick, pavers, and groundcover.
- Paved patios and decks must reflect the architecture of the home.)
- Stained color paving is acceptable (natural, neutral); however, painted paving is not allowed (colored red, white or black).

## Play Elements (Swings, Slides, Trampolines, Etc.)

- Play elements are allowed in rear yards. They must be hidden or screened from public view.
- Play elements behind picket fences must be screened from public view
- Trampolines behind picket fences must be in-ground and screened from public view.
- Additional screening may be required as determined by the Design Review Committee.

## Satellite Dishes

- Satellite dish or antenna should be installed in a location where it will cause the least nuisance or eyesore to the neighbors, while still providing an acceptable quality of signal.

Dish locations to be avoided include the following:

- The dish should not be placed on or along the roof ridge line.
- The dish should not be placed on or along the front leading corner edge on either side of the house.
- The dish should not be placed or located anywhere on the front of the house.
- The dish should not be placed or located anywhere within the front yard.

Dish locations to be encouraged include the following:

- Placed on rear facing, lower portions of the \_roof or roof eve line.
  - Side wall or back of house.
    - A pedestal stand in the rear or side yard.
  - Side of house adjacent to the area that already contains utility fixtures, such as electric meter, placed on the outside wall of the house at least 5 feet back from the front corner of the house.
- FCC rules presently apply only with respect to property over which the owner has exclusive use or possession. The Daybreak Community Association retains the right to

restrict the placement and location for the installation of a satellite dish or TV antenna on the outside common areas of all buildings.

- Refer to the [Satellite Placement Guide](#) on [www.MyDaybreak.com](http://www.MyDaybreak.com) for further instruction.

### **Shade Coverings/Shade Sails/Screens**

- This is considered a seasonal item and must be removed during the winter months. If it falls into disrepair or fading it must be removed.
- Retractable awnings must stay retracted during the winter months.

### **Sheds**

- Storage sheds are allowed in rear and side yards only and may not be built within or encroach in the property setbacks of the recorded plat.
- Storage sheds that are located in view of the street, open space or adjoining property must be constructed from similar materials and colors as the exterior of the house and match the architectural style of the residence.
- A non-matching shed must be enclosed within a fenced rear or side yard and may not exceed in total the height of the fence. If the location and placement of the shed is viewable from properties, then evergreen shrubs must be located on the sides of the shed that are viewable from the adjoining property.
- A site plan showing the location of the proposed shed, along with an architectural plan set, including elevation details must be submitted. Information that includes materials, dimensions and demonstrating compliance with these guidelines must be submitted prior to the construction or placement of the storage shed. All sheds are subject to review and approval by the Design Review Committee.
- Sheds may not be constructed using T1-11 siding
- [See Storage Shed Design and Placement Addendum](#) to Architectural Guidelines on [mydaybreak.com](http://mydaybreak.com)

### **Shutters**

- Shutters must complement style and architecture of the home.
- Appropriate sizes are as follows: each shutter must be equal to one half the size of the adjacent window. Single attic windows shutters may be equal to the size of the window.
- The color of proposed shutters must be approved by the Design Review Committee
- If removal of shutters is proposed, window trim must be installed, if not present.
- If window trim is present, it must be removed before the installation of shutters may occur so as not to create a gap between shutter and window

### **Sport Courts**

- Sport Courts including but not limited to basketball must be approved by the Design Review Committee. Sport courts are considered a major modification and are subject to the Design Review process. Please refer to the process as outlined on page 6 of this document.

### **Trash Enclosures (See Appendix)**

- Trash enclosures must be of similar form, material and color as the privacy fence on the property if present.
- Screening must exceed the height of the receptacle by 1' and must not exceed a height of 6'.

- Side drive and front recessed lots should have enclosures between the driveway and the side property line, located as far back as practical.
- Alley Lots must screen trash by placing receptacles behind the privacy fence, within an enclosed trash storage area.

### **Vegetables, Fruits, Herbs etc. (Updated 6/2023)**

- Vegetables and the like may only be planted in raised planter boxes, etc., and must be behind an approved 6' privacy fence or approved "living" fence/screening hedge.
- Vegetable boxes and vegetables, etc. may not be visible above the fence or screening hedge.
- Vegetables, etc., may not be used in place of required plant material, such as but not limited to foundation plants.
- Fruit trees may only be planted in rear yards and do not require approval as long as they are planted at least 6' from the property line and the fruit is harvested and not on the ground.
- Raised planter boxes do not require pre-approval as long as they meet the criteria outlined in this section. Compliance with this section is to be determined by the DRC, Board of Directors or Compliance Committee.
- Note: fencing and any "living" fence/screening hedge are still required to be approved prior to installation.

### **Water Features (Pool, Hot Tub/Spa, Pond, Etc.)**

- Water features are allowed.
- Pools, hot tubs, spas, etc. must be screened from public view and are not allowed in front yards or street side yards unless screened by a solid fence and placed in a location so as to minimize impacts on neighbors.
- Adhere to required setback requirements according to the city of South Jordan (The side yard setback is 5' from property line to water's edge)
- A 2' planter bed with screening is required
- A signed agreement from neighbor(s) regarding pool installations is strongly recommended to be included with required design review application
- Approval is required by Design Review Committee.

### **Window Boxes**

- Are subject to DRC approval and must complement the architectural style, color, proportion of windows and character of home.
- No plastic or vinyl allowed.

# Sustainable Landscapes

Daybreak is committed to being a sustainable community by seeking a balance among social, economic and environmental conditions. Daybreak integrates sustainable landscape practices at the single-family-lot and multiunit development scale by reducing the urban heat island effect, conserving water, and reducing storm water runoff.

## Reduction of Heat Island Effect

Daybreak was developed with wide park strips, green landscaping and lawns with intention. We recognize the need to use water wise planting and want to reduce “heat island effect”. An urban heat island (UHI) is an urban area or metropolitan area that is significantly warmer than its surrounding rural areas. This can be due to large expanses of impervious surfaces and the corresponding reduction in vegetation that result in increased ambient temperatures – especially during the hot, arid Utah summers. Thoughtful design and implementation of the landscape can greatly reduce the heat island effect generated by buildings and paved surfaces including the installation of trees and vegetation.

Areas of unplanted rock, mulch or gravel in front yards or park strips are not allowed in Daybreak. With the above in mind, the landscape requirements for areas of rock, mulch, concrete, gravel etc. are as follows:

- The park strip must be planted with 80 - 100% coverage of approved plant material at maturity – see appendix for park strip flip criteria
- Irrigation is required.
- Individual drip irrigation lines are required to each plant and tree
- Evergreen foliage must be included for year-round interest.
- Bark mulch must be shredded, natural, neutral in material and dark brown or black in color and blend with surrounding landscaping.
- Dark brown or black shredded rubber mulch is approvable
- Rock mulch must be decorative, natural, neutral, gray or beige/brown in color and blend with surrounding landscaping. Rock mulch must be no more than 1” to 2” in size. (no red, black or white rock allowed) – not allowed in front of home or in visible side yards
- See Guidebook regarding requirements for sections of rock, mulch and concrete additions.

## Water Conservation

The large number of attached and smaller detached homes lots have already contributed to water conservation in Daybreak. Most household water is used for yard irrigation. Through careful planning and design using water wise plant materials, the amount of water needed to support the landscape can be greatly reduced, resulting in resource conservation and cost savings.

- Use water wise plant material to reduce landscape water demand.
- Utilize water-efficient irrigation systems such as smart irrigation controller, low flow sprinkler heads and drip irrigation.
- Mulch planting beds to maintain soil moisture, minimize evaporation, reduce weed growth and keep plant roots cool.
- Limit turf areas that require a lot of supplemental watering.
- Improve soil so that it can better absorb the water and encourage deeper roots.



# Reduction of Storm Water Runoff

Permeable ground surfaces allow for the exchange of water and air, thus recharging the groundwater table and aerating the soil. To allow this process to happen most effectively, large expanses of paving should incorporate pervious materials and plant materials when possible.

- Evaluate the circulation pattern and impact of the site to reduce the total amount of impervious surfaces.
- Impervious paving should be utilized on only the heaviest trafficked areas.
- In areas of high circulation, utilize permeable surfaces such as pavers and flagstone.
- Pavers, crushed fines, or gravel may be used in areas of less intensive use.
- Employ a “Hollywood Drive”, sometimes also called a “tire tracks” driveway in which masonry paver units are utilized for where the tires of the to allow water to permeate through.

# Fencing Guidelines

Fences help to define the edges of yards and give privacy to side and rear yards. At Daybreak, they are considered background elements that help to highlight landscaping and architecture.

- All fencing updates or changes are subject to approval by the Design Review Committee
- All fence applications must include a plan depicting where the exact location of the fence is being proposed. Please see example in Fencing Application.
- All fence applications must include a Blue Stake Report.

## Fencing Material

- Cedar Fencing with [Cabot's bleaching oil or Cabot's Stain or other Daybreak approved Gray stain](#). ("Driftwood" gray in color) See [mydaybreak.com](http://mydaybreak.com) for 3 approved gray options.
- Tan vinyl fencing allowed in East Lake and Founders Village ONLY

## Front Yard Fencing

- 6-foot privacy fences are not permitted in front yards
- 6-foot privacy fences are not permitted on front corner and side corner lots
- 36-inch picket fences are permitted
- All front yard fencing should be consistent with the architectural style of the house.
- Front yard fencing picket design must be specified in the application
- Vinyl picket fencing material is not permitted

## Rear Yard & Interior Side Yard Fencing

- Rear yard & Interior side yard fencing is optional.
  - Maximum height 72 inches from finish grade on high side of yard;
    - Top 18 to 24 inches of 72-inch fence facing streets and/or public space requires change in articulation and 40% opacity (semi-private fence).
    - Fences facing neighboring back and side yards may be 72-inch privacy design.
  - Setback Requirements
    - Double fencing is not allowed.
    - 5 feet from front façade of house (porch excluded) and neighboring home's front façade
    - 25 inches from alleyway
    - Rear façade setback – at least 1 foot behind rear corner(s)
    - Variances for setbacks may be approved on a case-by-case basis by the Design Review Committee

## Screen (See Appendix)

- A screen may be required to block private or utility areas from public view.

See appendix (x) for design details

### **Street Side Yard Fencing (Single Family Lots Only)**

- Side yard fencing is optional
- 6-foot privacy fences are prohibited on side yards adjacent to public streets
- Maximum height is 36 inches
- Setback Requirements
  - At least 1 foot back from rear corner of house
  - 2 feet from sidewalk and must be planted on both the interior and exterior of the fence with a 2-foot planter bed
- Contact the Association office at 801-254-8062 for specific conditions where fencing is allowed depending on product type.

### **Street Side Yard Fencing (Townhomes and/or Condominiums)**

- Side yard fencing is optional however, special lot conditions apply.
- Contact the Association office at 801-254-8062 for specific conditions where fencing is allowed depending on product type.

### **Trash Enclosures (See Appendix)**

- Trash enclosures screen trash and recycling receptacles from common views.
  - If a trash enclosure is constructed it must include a concrete pad sized to accommodate two standard sized municipal trash/recycling cans and fencing material to screen the cans from public viewing.
  - Trash enclosures are required to match material and color of the privacy fence on home.
  - Trash enclosures must be open rail if street or alley facing
  - Screening must exceed the height of the receptacle by 1 foot and must not exceed a height of 6 feet.
  - Trash containers may be kept behind a fence if a trash enclosure is not preferred.

# Fence Design Requirements

Fences at Daybreak are made up of several required elements; pilasters (posts); horizontal rails at bottom, waistline, and top; and infill boards called the “main body” and “upper body”. Fencing may be site- constructed or prefabricated, in module widths between 6 and 9 feet. Except for pilasters, all fencing components should be visually consistent with common lumber sized and construction. Depending on the slope of the lot, the DRC will determine whether fence stepping is required, or fence sloping will be allowed. Fence design may be altered depending on architectural styles. All fence installations must be approved by the Design Review Committee for Daybreak prior to installation.

## Pilasters

- Pilasters should be sized appropriately to their material; for example, wood products in 6" x 6".

## Caps

- Caps on pilasters are required and need to match the fence style.

## Rails

- Rails must be expressed externally to the body on the public side of the fence along alleyways, parks, streets, and open spaces. Bottom and waistline rails must be at least 4 inches on the are commonly 1x4 or 1x6 members. Top rails are often smaller elements, in keeping with a finer scale in the upper body.
- The main body of the fence may fully block views in order to create privacy in back yards. The upper body is in the top 18 inches to 24 inches of the fence, and may be solid when facing other lots, but must have a transparency of at least 40% when facing streets, alleys, or other public spaces.
- Rails must be 4 inches wide and ¾ inch thick.

# Architectural Guidelines

All landscaping and architectural modifications must be approved by the Design Review Committee for Daybreak prior to installation. It is a general rule that all architectural modifications must complement/match the current architectural style of the home.

## Chimneys

- Must match the architectural style of the home.

## Cladding

- T1-11, vinyl, or aluminum siding materials are not allowed.

## Color

- Daybreak residents are required to submit color palettes and physical paint chips with their application for the Design Review Committee approval if they intend to change the colors which are currently on their home. Daybreak residents do not need to seek an approval to re-paint when the existing colors and application pattern are not going to change. As part of the Design Review submittal process, Daybreak residents are required to submit the following:
  1. A full colored exhibit of the front, sides, and rear elevation specifying all colors to be used in the proposed re-painting of the home. The elevations should clearly demonstrate the application of the proposed paint colors by identifying the application of the main body, trim and accent color(s) associated with the re-painting plan.
  2. An exhibit demonstrating there are no similar colors in any view corridor proximate to the subject property.
  3. All color selections and locations must be approved prior to installation.

Color application is a key component of style and a powerful device for creating variety among plans and elevations. These examples illustrate the three primary strategies for applying color to the main body, trim, and accents of a Daybreak Communities house.



**Contrasting**

**Tonal Monochromatic**

**Monochromatic**

### **Contrasting Palette**

- Trim, panels and other additive components are a distinct color from the main body of the house.
- White, light gray, or a complimentary color to that of the main body of the house are appropriate choices.

### **Tonal Monochromatic Palette**

- Trim, panels and other additive components are a similar color to the main body of the house but are lighter or darker tones compatible with the selected architectural style.

### **Monochromatic Palette**

- Trim, panels and other additive components match the color of the main body of the house.
- Monochromatic palettes using dark or rich colors are most successful when all of the elements of the house are Constructed of paintable materials.
- All color modifications must match the style of home. Style-specific colors are encouraged.
- Accessory elements shall not be painted to attract attention, and instead, should be painted to match the trim color. Chimneys not constructed with masonry are required to be stucco and either neutral in color or matched to the body color.
- Corner boards should match body color when using board and batten.
- Front doors may be painted an accent color, but the door jamb should remain trim color. Auxiliary doors should not be highlighted with accent colors. (Exception: Garden Park Village, original door jamb painted at construction)
- Trim, soffit, fascia, and railing should match. Houses built using paintable soffit and fascia will have a wider range of color scheme options than those with aluminum.
- Paints with a gloss finish are not permitted as an exterior main body color application.
- Shifts in color are limited to the following locations;
  - inside corners,
  - horizontal breaks and changes in material,
  - breaks between trim and wall plane,
  - gable ends and accent panels,
  - plane changes.
- Window colors are limited to white, taupe, and artisan window colors including, but not limited to red, green, silver, bronze, and black.
- Black trim, soffit, and fascia are not appropriate for a Daybreak Communities house unless the main body is of similar value. Dark trim colors are generally only appropriate in the European Romantic style.
- Shingles should be complementary to color scheme. When used, metal roofs are approvable only in Galvalume or matte bronze or zinc colors where stylistically appropriate.
- Existing, original color blocking should be considered when applying for a new exterior color modification

### **Columns**

- Must be consistent with the Architectural style of the home.

## Eaves

- Frieze board is 6 to 12 inches, either touching/lying on same plane with or no more than 8 inches above the window head trim.

## Front Doors, Garage Doors, Storm Doors and Security Doors

- Garage door height may be no taller than 9' and must be the same height of other garage doors on homeowners' property so as to not draw attention to a specific door.
- Color and style must match the architectural design of the home.
- Door slab ONLY may be painted; door frames and jamb must remain trim color except for builder installed and painted homes in Garden Park.
- Storm and security doors must match door jamb color or color of the front door.



### DO

The door is painted a special color, while the jamb and door trim are painted the trim color.

### DON'T

The door jamb and trim, as shown above in bright blue, should NOT be painted the door color.

Garage doors must be the home's primary trim color, or a Design Review Committee-approved accent color.

## Greenhouses

- Greenhouses are permitted. However - location, architectural style, and size must be reviewed and approved by the Design Review Committee. Greenhouses attached to the home are considered a home addition and are a major modification.

## Gutters and Downspouts

- Downspouts must be painted to match background house color, must be located away from prominent corners, and must drain away from window wells and foundations.
  - Common Material: Ogee profile gutters with round or rectangular downspouts or PVC is acceptable in a color that matches trim.
  - Custom Material: Half-round with round downspouts in Galvalume finish or copper.



## Masonry

- Never terminate at an outside corner or in the middle of a wall; masonry must terminate at an inside corner.
- Trim with an appropriate masonry water table detail.
- Headers or lintels must span openings.
- No wainscoting is permitted except for Founders and East Lake Villages.

## Porch and Stair Railings

- Allowed porch and stair railing materials include wood, metal or composite products. Vinyl is only allowable in Founders Park Village but is not recommended.
- All railing components shall be a single material.
- If contiguous with porch, stair railing must be same material
- Porch and deck railing should match in style, color and material
- A handrail that is not attached to the porch rail may be utilitarian, bar-rail style.
- All porch and stair railings are required to be painted using the primary trim color of the house. Consideration may be given to allowing for the use of an accent color subject to its conformance with the home's existing color palette, architectural style, etc.
- Railings must extend, return, and prohibited from "floating" in space.
- Porch balusters shall be spaced no more than 4-inches apart.
- In addition to adhering to the architectural style of the home, depending on the Village/District/Neighborhood, other materials and design elements may or may not be allowed.
- Black Metal railing is allowed in Springhouse Village with DRC approval
- Metal is strongly discouraged due to the nature of pitting, bubbling, rusting and the long-term durability, which is significantly less than a wood composite material. On-going maintenance and rust abatement is required.
- All porch and stair railings must be consistent with the architectural style of the home. The determination of consistency to architectural style shall be solely determined by the DRC and is not subject to appeal. Consistency requirement includes (but is not limited to) the rail details shown below:

## Colonial Revival

### RAIL DETAILS

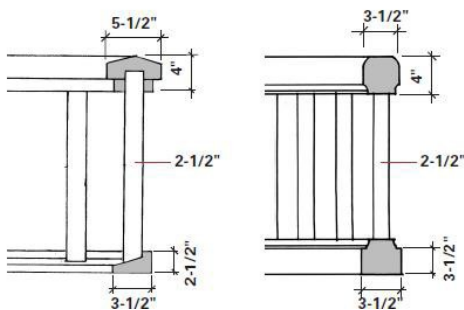

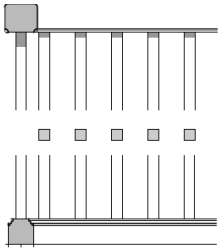

Square balusters, 3x min.

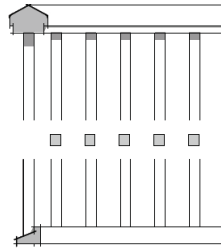

Square balusters, 3x min.

## Arts & Crafts (Craftsman)

### RAIL DETAILS

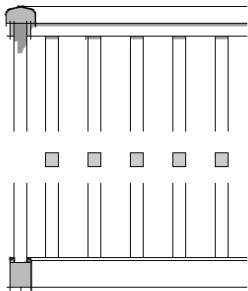
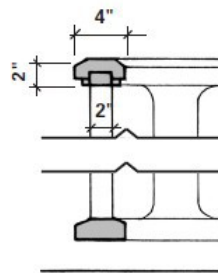
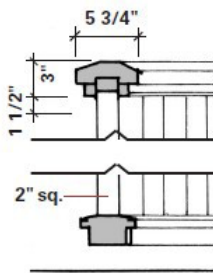
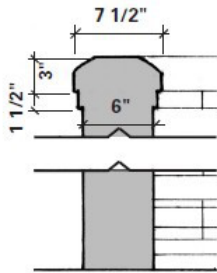

Square balusters, 3x min.

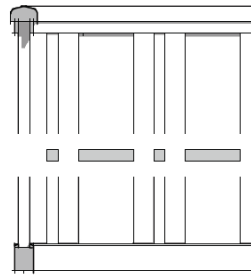

Alternating-width pattern of 2x balusters and panels

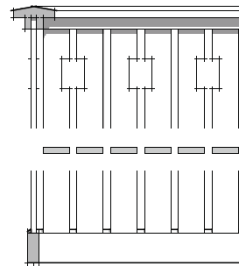

Wide, paired 2x balusters with repeating cut pattern

## European Romantic

### RAIL DETAILS

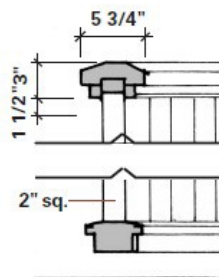
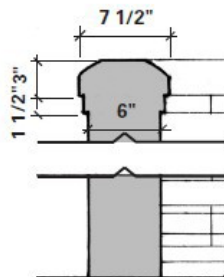
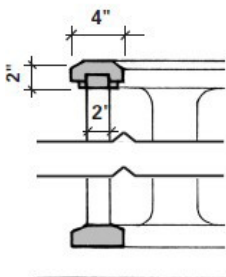

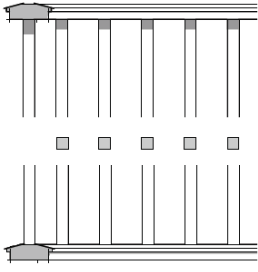

Square balusters, 3x min.

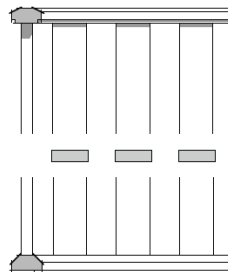

Rectangular balusters, 3x min.

## Farmhouse Victorian

### RAIL DETAILS

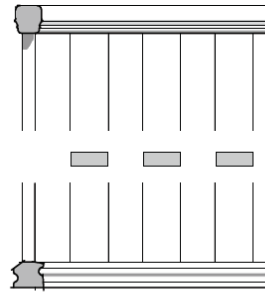
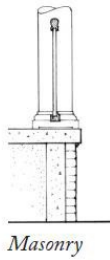
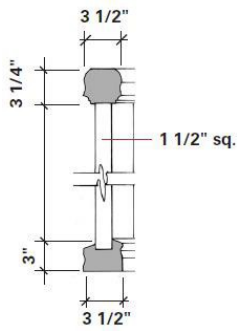

Rectangular balusters, 3x min.

## Modern

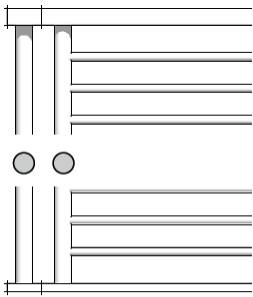

Horizontal balusters

## Radon Mitigation System

- Radon mitigation systems are approvable.
- Pipe may need to be painted the house color as to reduce visibility and match the home's aesthetic.
- If the above conditions are met, no Design Review Committee approval is necessary

## Roofs

- Roof penetrations and flat skylights may be placed on a roof not facing public thoroughfare, maximum of two skylights per roof plane.
- Roof vents of any kind must be painted to match roof shingles.

## Shingles

- Weave at corners or terminate with appropriate corner trim board or use artisan corner clips.

## Siding

- No raised grain permitted.

## Soffits

- Aluminum soffits and fascia materials are not permitted in custom details and discouraged in others.
  - Common Material: Smooth fiber-cement boards.
  - Custom Material: Tongue and groove.
  - Soffit and fascia must match trim.

## Solar Panels

- Solar panels are permitted. However, location must be approved by the Design Review Committee as this is an exterior modification to the home.
- Orderly, block formation placement, in the least visually distracting manner and location is highly recommended.
- Solar panel electrical boxes must match the surrounding exterior color of the home.

## Storm/Security Doors

- Must be clear, solid glass pane only with no decorative etching or design.
- Storm and security doors must match the door or trim color

## Trellis and Pergolas

- See Garden Structures (Trellises, Pergolas and Arbors section on page 16

## Trim

- Transitions between materials must be trimmed and flashed in a manner appropriate to the style.

## Windows

- Slider windows are not permitted on any public facing elevation except for Founders Village
- The addition of windows must match existing windows on home

- Windows must match the architectural style of the home and must be approved by the Design Review Committee.
- Horizontally oriented windows are discouraged where visible from public areas.

# Prohibited Plants and Trees in Daybreak

Most plants and trees are permitted in Daybreak; however, below is a list of species that are prohibited on residential properties due to their noxious and evasive growing habits.

Aspen Trees  
Cottonwood  
Palm Trees  
Russian Knapweed  
Hoary Cress  
Musk Thistle  
Diffuse Knapweed  
Russian Olive Tree  
Yellow Star Thistle  
Spotted Knapweed  
Squarrose Knapweed  
Canada Thistle  
Field Bindweed  
Bermuda grass  
Quack grass  
Leafy Spurge  
Dyers Woad  
Perennial Pepper  
Weed Poplar Trees  
Purple Loosestrife  
Scotch Thistle  
Siberian Elm  
Perennial Sorghum  
Johnson grass  
Medusa head

# Definitions

**Annual:** Plant that lives only one growing season.

**Backflow Preventer:** It is a Utah State Law to obtain a backflow preventer device and have it inspected annually. A back flow prevention device is used to protect water supplies from contamination or pollution. Many types of backflow prevention systems also have test cocks so that they can be tested or examined to ensure they are functioning properly.

**Baluster:** A short pillar or column, typically decorative in design, in a series supporting a rail or coping.

**Boulder:** A large, rounded mass of rock at least 24 inches in width.

**Caliper:** The diameter (width) of a tree measured at 6 inches above the base or root of the tree.

**Composite: (wood)** I.e.: composite railing is generally made of material such as plastics and very fine wood saw dust, which are mixed and compressed with intense pressure and heat. This must be specific to architectural style, paintable, simulating wood grain and matte in finish.

**Deciduous:** A tree that sheds or loses leaves at the end of the growing season.

**Door Frame:** The entire framework supporting the door, including the sill, jamb and head. This is also known as a door sash.

**Door Jamb:** The interior sides of a door frame—specifically the parts of the frame that hold the mounting hinges on one side and the strike plate for the latch on the other.

**ET Manager:** ET or Evapotranspiration is the amount of water lost from the soil through evaporation plus the plant's water loss (known as transpiration). The ET Manager detects information every hour and waters the soil when needed.

**Edger/Header:** A continuous edge between lawn and planting bed.

**Fascia:** A wooden board or other flat piece of material such as that covering the ends of rafters.

**Fallow:** Not in use; inactive.

**Frieze board:** A horizontal (or angled when installed on gables) trim board installed flat against the wall and which covers the gap between the top of the siding or brick facade and the soffit.

**Galvalume:** A coated steel.

**Hollywood Drive:** A strip of paving or planting area in the center of the driveway.

**Impervious:** A surface that does not allow water to pass through.



**Irrigation Controller:** A controller that is set to determine when to turn on your sprinkler system.

**Ogee:** A double curve with the shape of an elongated S.

**Opacity:** A degree to which a substance is not transparent or translucent.

**Perennial:** A plant that lives more than one growing season throughout the years.

**Pergola:** An arbor formed of trelliswork supported on columns or posts, over which vines or other plants are trained.

**Permeate/Permeable:** To pass through or into.

**Pervious:** A surface that permits water to pass through.

**Purlin:** A horizontal beam along the length of a roof, resting on a main rafter and supporting the common rafters or boards.

**Soffit:** The underside of an architectural structure such as an arch, a balcony, or overhanging eaves.

**Terrace:** A raised level with a vertical or sloping front or sides faced with masonry, turf, or the like, esp. one of a series of levels rising one above another.

**Temporary:** For these guidelines, temporary is any item(s), visible from public view, and lasting for only a limited period of time, non-permanent, short-term, easily removable and stored when not in use, as to not distract from the aesthetics of the community. (examples: hammocks, toys, bikes, pet fencing or enclosures) These items should be removed by the end of the day when not in use.

**Trellis:** A structure of open latticework, especially one used as a support for vines and other creeping plants.

**Variance:** An official permit granted by the Design Review Committee and the Board of Directors to allow something that is normally not permitted by regulations.

**Vinyl:** A synthetic, plastic or PVC made using synthetic plastics, such as polypropylene, nylon, polythene (polyethylene) or from various recycled plastics.

**Wainscot:** An area of paneling on the lower part of a wall.

# Flip The Strip

With careful execution and approval by the Design Review Committee, a xeric or sustainable water wise landscape can be a beautiful addition and meet all the requirements outlined in our Resident Design Guidelines.

If you are considering “**flipping the strip**” or incorporating a water wise landscape into your existing park strip, the following guidelines will help you get started.

1. Any landscape modification must be applied for and approved by the Design Review Committee. Please contact the Daybreak Community Association office for an application form and to schedule a consultation. Applications may also be found on [mydaybreak.com](http://mydaybreak.com).
2. A water wise landscape does not mean a plant or maintenance-free landscape.
3. At least 80 to 100%, at maturity, of your park strip must consist of plant material with a variety of colors, sizes and textures for year-round visual appeal.
4. Drip irrigation is required; trees must be separately irrigated.
5. Steel edging is required to separate water-wise areas from turf, especially at property line.
6. Dark brown, shredded, organic mulch or rock mulch may be used as a ground covering.
7. Colored or rubber mulch (red) is prohibited.
8. Rock mulch must be neutral in color and 1-2" in size (No black, red or white rock)
9. It can take up to two years for a water wise landscape to be fully established.
10. During the establishment period, your landscape will need to be watered frequently.
11. Fall is an excellent time to plant your water wise landscape to limit water usage while new plants are being established.
12. Ground cover or plant material must be included under tree canopies.
13. Dwarf variety for shrubs is strongly encouraged

Please contact the Association office if you have additional questions or would like to schedule a consultation.

# Appendix

See the link below for additional resources and updates regarding the design review policies.

[https://www.mydaybreak.com/master\\_association/governing\\_documents.php#outer-151](https://www.mydaybreak.com/master_association/governing_documents.php#outer-151)

Should you have additional questions, please reach out to the Daybreak Community Association at 801-254-8062.